

#lifeatbit

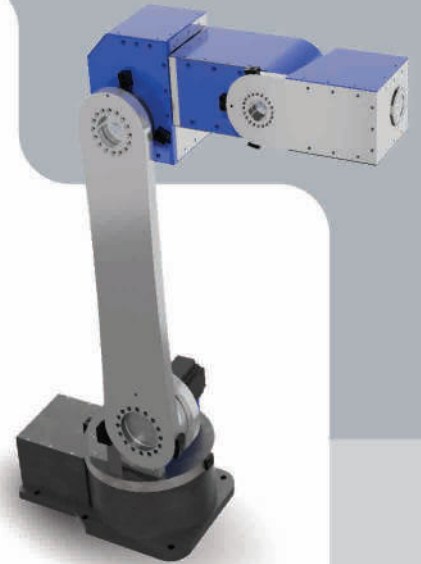

What do we Offer?



Introducing our Six Axis Quantum Robot V1.0 & V2.0 – the epitome of precision and efficiency in manufacturing. Engineered for unmatched accuracy, it optimizes workflows and boosts productivity. With cutting-edge technology, our robot delivers reliable, adaptable, and high-performance solutions, revolutionizing automation and setting new standards in production efficiency.



Enhanced Motion Precision

-  Equipped with cutting-edge servomotors
-  Precisely engineered joint mechanisms
-  Execute intricate tasks with unparalleled accuracy

Applications

- Loading / Unloading
- Painting

Controlled axes	6	
Rated Payload	5 kg	
Repeated Positioning Accuracy	±0.05 mm	
Body Weight:	65 kg	
Input Voltage:	230V, 50Hz	
Radius of Motion	1190 mm	
Working Range	J1	170° ~ -170°
	J2	90° ~ -50°
	J3	60° ~ -90°
	J4	180° ~ -180°
	J5	130° ~ -130°
	J6	± 360°

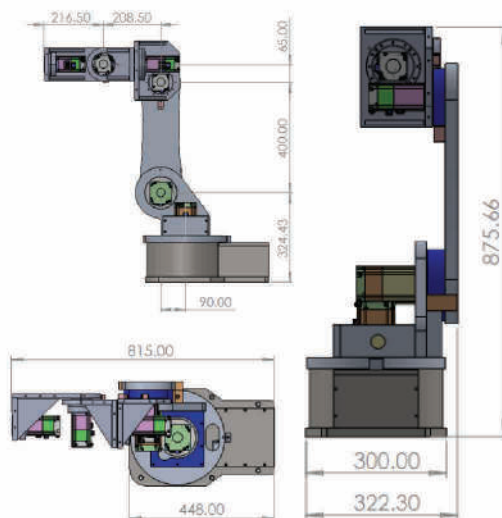

Controlled axes	6	
Rated Payload	10 kg	
Repeated Positioning Accuracy	±0.05mm	
Body Weight:	70 kg	
Input Voltage:	230V, 50Hz	
Radius of Motion	900 mm	
Working Range	J1	-170° ~ +170°
	J2	-58° ~ +125°
	J3	-182° ~ +57°
	J4	-180° ~ +180°
	J5	-90° ~ +90°
	J6	± 360°